

(No Model.)

3 Sheets—Sheet 1.

C. SEESSLE & G. W. LEIMAN. LATHE.

No. 358,945.

Patented Mar. 8, 1887.

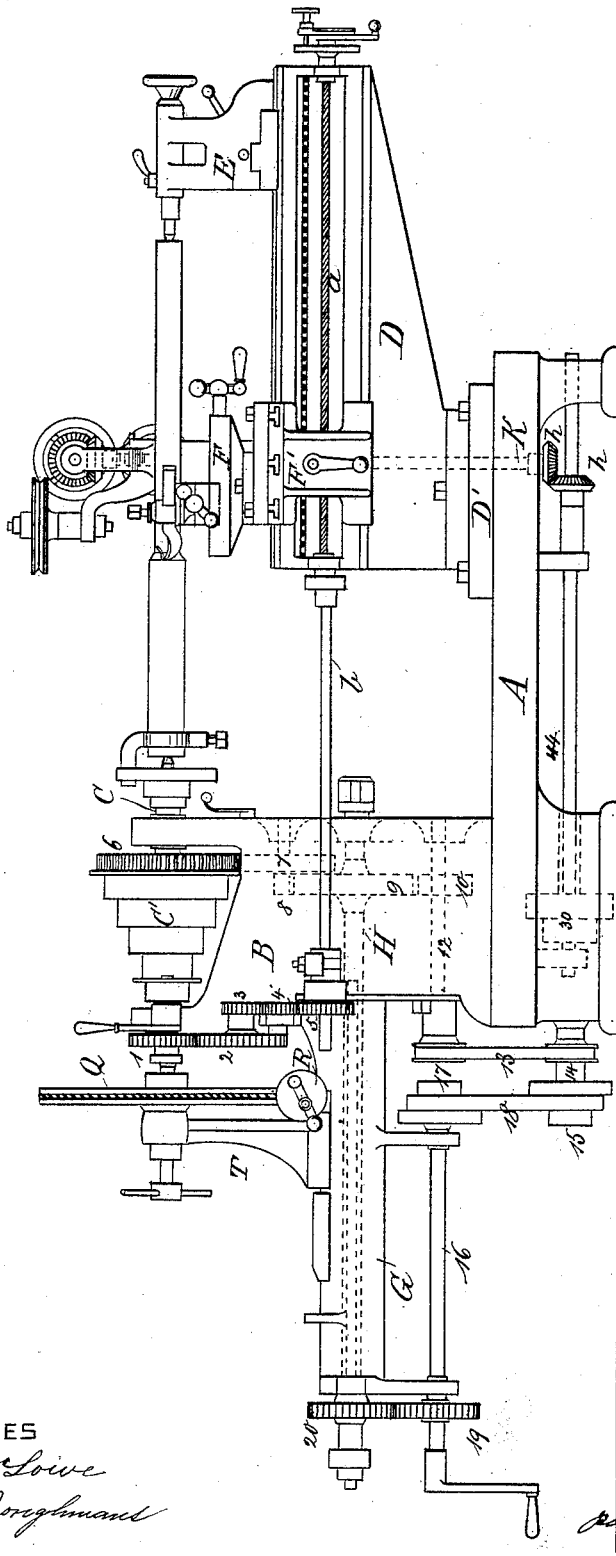

FIG. I.

WITNESSES

Wm. A. Love
Alfred Joughmans

INVENTOR

Charles Seessle &
Georg W. Leiman
per Pender & Brindes
Attorneys.

(No Model.)

3 Sheets—Sheet 2.

C. SEESSLE & G. W. LEIMAN.
LATHE.

No. 358,945.

Patented Mar. 8, 1887.

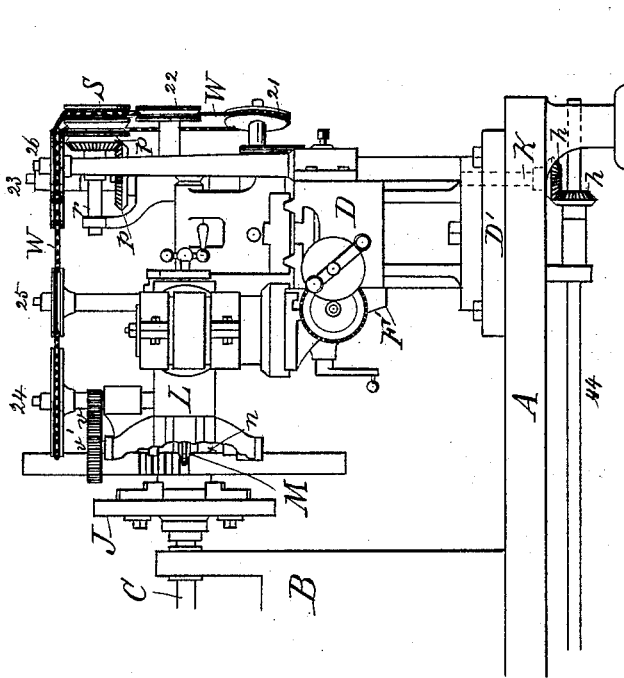

FIG. II.

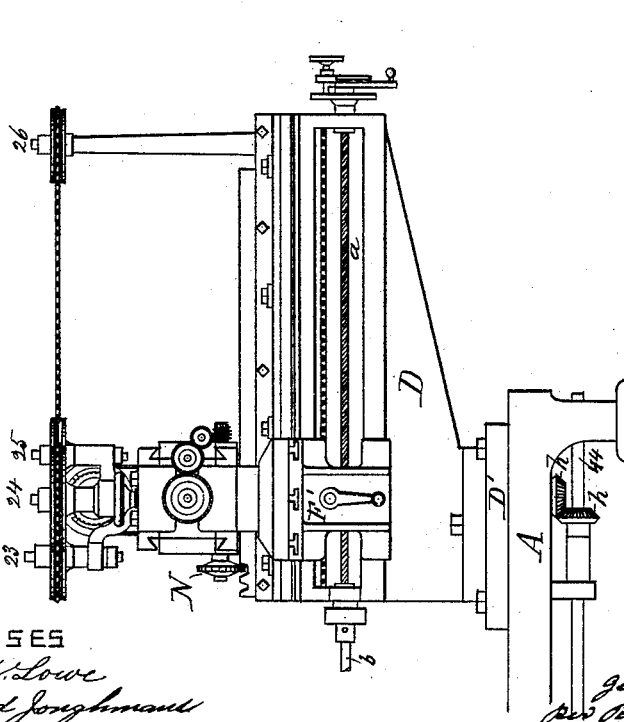

FIG. III.

WITNESSES

Wm. H. Lowe
Alfred Joughmans

INVENTOR

Charles Seessle and
George W. Leiman
Per Pender & Perkins
Attorneys.

(No Model.)

3 Sheets—Sheet 3.

C. SEESSLE & G. W. LEIMAN.
LATHE.

No. 358,945.

Patented Mar. 8, 1887.

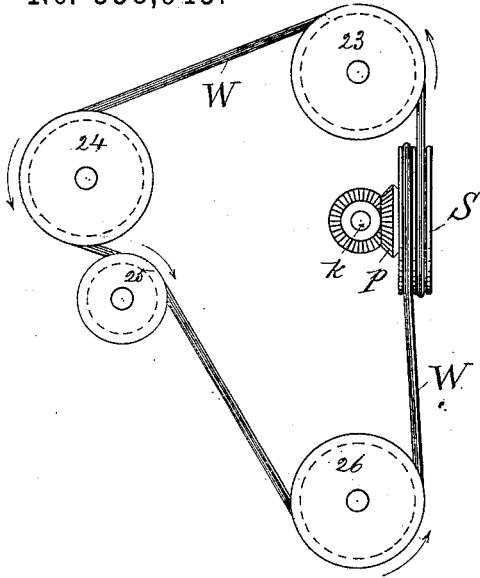

FIG. VI.

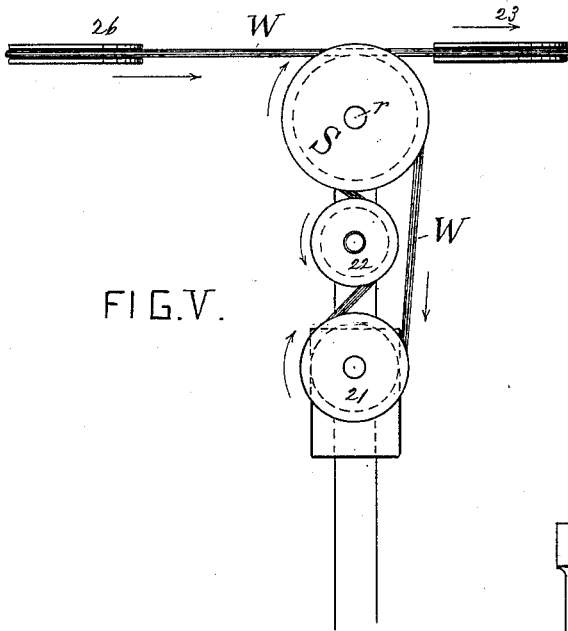

FIG. V.

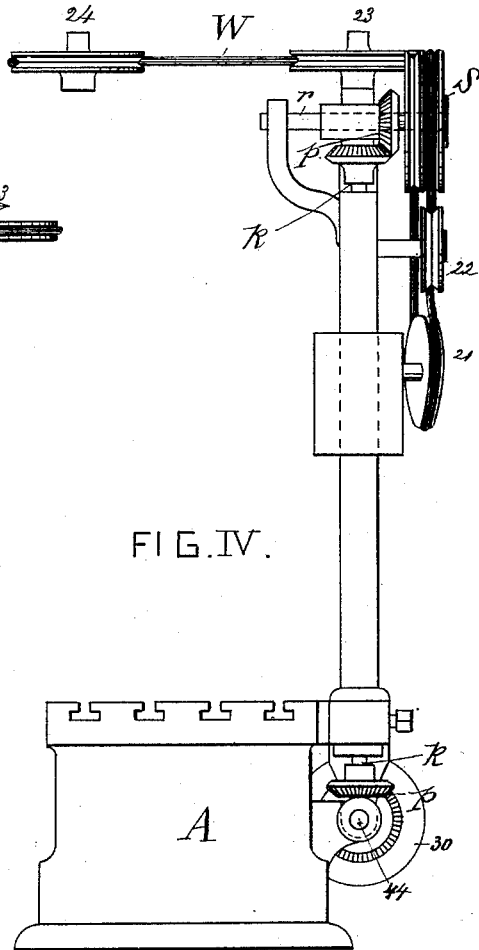

FIG. IV.

WITNESSES

Wm. A. Lowe
Alfred Joughmans

INVENTOR

Charles Seessle, George W. Leiman
per Rueder & Bissel
Attorneys.

UNITED STATES PATENT OFFICE.

CHARLES SEESSLE AND GEORGE W. LEIMAN, OF NEW YORK, N. Y.

LATHE.

SPECIFICATION forming part of Letters Patent No. 358,945, dated March 8, 1887.

Application filed November 2, 1886. Serial No. 217,776. (No model.)

To all whom it may concern:

Be it known that we, CHARLES SEESSLE and GEORGE W. LEIMAN, both of New York city, New York, have invented a new and useful Improvement in Lathes, of which the following is a specification.

This invention relates to a turning-lathe, combined with various attachments enabling the boring out of cylinders, the cutting of gear-wheels, and the facing out of keys or teeth as may be required.

The invention consists of the various improvements hereinafter more fully described.

In the accompanying drawings, Figure I represents a front view of our improved lathe. Fig. II represents part of the lathe when arranged for cutting teeth into a gear-wheel. Fig. III represents part of the lathe arranged for cutting teeth into a straight bar or for cutting key-seats. Figs. IV, V, and VI show the arrangements for driving the cutting-tool for cutting teeth, &c., in front and side view and plan, on an enlarged scale.

A is the bed-plate or frame, on one end of which the head-stock B is firmly attached, containing the mandrel C, with cone-pulleys C', and gearing arranged in the usual manner. At the other end of the frame A is a frame, D, capable of turning on a central horizontal pin or a plate, D', and arranged to receive the tail-stock E, with dead-spindle and support F, when arranged for turning shafts, &c., as shown in Fig. I. By this arrangement of supporting the head-stock upon a frame independent of the frame which forms the bed-plate for supporting the tail-stock and support a comparatively light lathe is made, while at the same time great depth will be obtained for swinging large wheels.

The carriage F' of the support receives its motion, in the usual manner, through screw a, connected to a shaft, b, operated by the changeable gearing 1 2 3 4 5 at the end of the head-stock. At the end of the head-stock B a sleeve, G, is attached, in which the boring-bar H is fitted, receiving its motion from the mandrel C and gear-wheels 6 7 8 9. The feeding motion of the boring-bar H is obtained from motion communicated from wheels 9 and 10, shaft 12, connected through belt 13 with shaft

14, cone-pulleys 15 and 17, connected through belt 18, shaft 16, and gearing 19 and 20, operating the boring-bar in the usual manner.

To cut the teeth in gear-wheels, the wheel is attached to a face-plate, J, fixed upon the mandrel C. The support F is removed from its carriage F', and the frame D is turned on its plate D' so as to stand at right angle with the frame A. (See Fig. II.) A support, L, is attached to the carriage F', carrying the shaft n for the cutting tool or wheel M. Motion is communicated to this shaft n, carrying the cutting-wheel M, from shaft 14, connected through bevel-wheels h with an upright shaft, k, on the upper end of which bevel-wheels p give motion to a horizontal shaft, r, carrying double-grooved wheels s. From these grooved wheels s the motion is communicated by a round endless belt, W, passing around grooved pulleys 21, 22, s, 23, 24, 25, and 26, and back to one of the wheels s. The spindle-carrying wheel 24 is connected through changeable gear-wheels v v' with the shaft n, carrying the cutter-wheel M. (See Figs. II, IV, V, and VI.)

To turn the wheel attached to the face-plate J the exact distance of the pitch of the teeth, a support, T, is arranged capable of sliding upon the sleeve G and carrying a worm-wheel, Q, with worm and indicating-plate R. (See Fig. I.) The spindle of this worm-wheel Q is connected with the mandrel C when teeth are to be cut into a wheel by moving the support T, and thereby the exact division for the required number of teeth is obtained.

To cut teeth into a horizontal bar or to cut keyways, a cutting-wheel, N, is arranged upon a horizontal spindle attached to a support attached to the carriage F', while the rod into which the teeth are to be cut or the shaft into which a key seat or groove is to be cut is attached to the face of the frame D, (see Fig. III.) motion being communicated to the cutter-wheel N in a similar manner as above described for operating the cutter-wheel M.

What we claim as our invention is—

1. The combination of head-stock B, spindle C, pulleys C', and spindle-gearing with boring-bar H, supported in sleeve G, and with means for turning and feeding said boring-bar, which consist of gearing 6 7 8 9 10, shaft 12, belt 13, 100

shaft 14, pulleys 15 17, connected by belt 18, shaft 16, and gearing 19 20, substantially as described.

2. The combination of head-stock B, spindle
5 C, pulleys C', and spindle-gearing with support L, carrying spindle *n* and cutter M, operated by intermediate gearing frame-shaft, *k*, said shaft being revolved by intermediate gearing from the spindle-gearing, substantially
10 as specified.

3. The combination of head-stock B, spindle

C, pulleys C', and spindle-gearing with frame D, turning on plate D' and supporting tail-stock E and slide-rest F, said slide-rest supporting the cutting-tool, substantially as set
15 forth.

CHARLES SEESSLE.
GEORGE W. LEIMAN.

Witnesses:

F. V. BRIESEN,
HENRY E. ROEDER.